

VX305C-40G

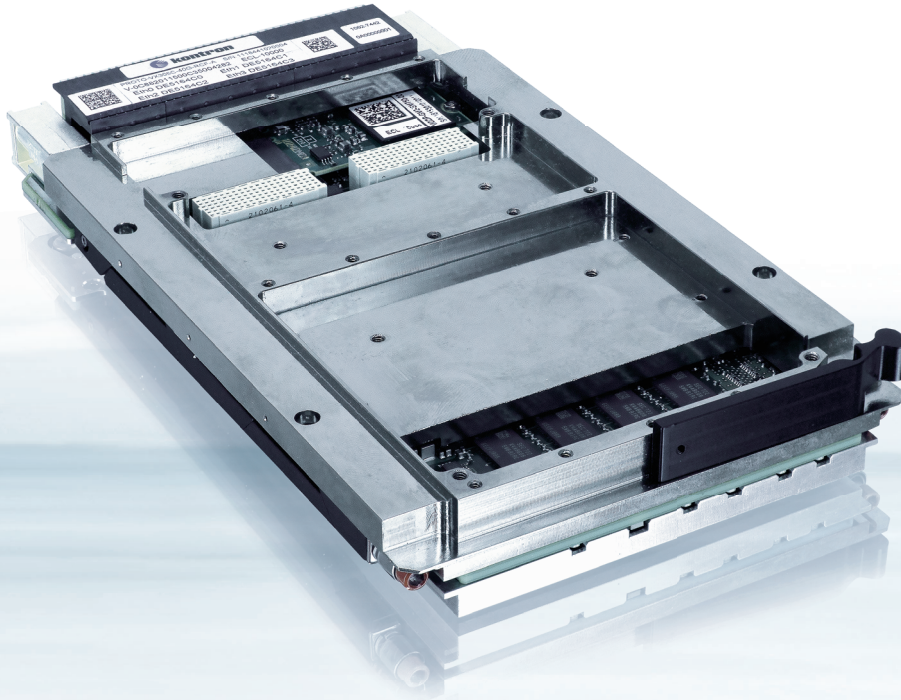

Twelve Core Intel® Xeon® Processor VPX Server Blade

- ▶ 12 Core Xeon® Processor D, up to 32 GByte DDR4 with ECC
- ▶ 40 Gigabit Ethernet Data Plane, Dual 10 Gigabit Ethernet Control Plane
- ▶ x8 PCI Express® Gen3 XMC slot, x4 PCI Express® Gen3 Expansion Plane
- ▶ Extra 10 Year* Extended Life Cycle
- ▶ Developed in alignment with the SOSA™ Technical Standard

*after main silicon EOL (see Kontron LTS offering)

POSSIBILITIES START HERE



VX305C-40G

Server-Class Power Combined with Rich I/O

Featuring the 12 core version of the Intel® Xeon® D processor family (formerly Broadwell-DE) and developed in alignment with the SOSATM technical standard, the VX305C-40G is an I/O intensive SBC compliant with the VITA 65 (OpenVPX) slot profile SLT3-PAY-1F1F2U1TU1T1U1T-14.2.16. The VX305C-40G combines server-class processing with rich I/O featuring a 40 Gigabit Ethernet data plane (40GBASE-KR4), a 4-lane PCI Express Gen 3 expansion plane, dual 10 Gigabit Ethernet control planes (10GBASE-KR), along with USB (2 and 3), SATA3, serial links, video (HDMI, with DisplayPort available in 2019), GPIO, and an 8-lane PCI Express Gen 3 XMC slot, with XMC I/O mapping to the backplane (P1w9-X12d+P2w9-X16s+X8d). The result is a powerful, flexible, single board computing platform suitable for a wide range of embedded applications.

Ideal for Virtual Machines and HPEC Applications

At the silicon level, the Xeon® D platform server heritage allows for advanced applications such as virtual machines and software containers. It can run diverse software workloads which dynamically share common resources or strictly bind to pre-defined resource usage profiles. Application can easily adapt to hardware evolution such as CPU count, memory, I/O availability, or even form-factor. Virtualization and container technologies enabled by the Xeon D processor transform embedded solutions into a future-proof solution, preserving investment into an application code base.

Typical demanding applications include:

- ▶ Radar, sonar, and other sensor processing applications
- ▶ Imaging systems
- ▶ Airborne fighter and UAV radar
- ▶ Long term programs in harsh environments

Long Term Programs: High reliability, low TCO

Kontron provides a robust program to increase reliability and to lower Total-Cost-of-Ownership (TCO) for VX305C-40G. Intel silicon

reliability is 10 years, but Kontron offers a Long Term Supply service (LTS) for over 15 years. A comprehensive Health Management program is optionally available to support easy multi-year field maintenance. All this makes the VX305C-40G the ideal candidate for long term programs, and brings server class applications into the battlefield for many years to come.

VITA 46.11 Health Management

The VX305C-40G features a VITA 46.11 compatible Intelligent Platform Management Controller (IPMC) for centralized system health management. Supporting Tier-1 and -2 commands (and more), the Kontron-designed IPMC (both hardware and firmware), along with a comprehensive and flexible Power-On Built-In Test (PBIT) package brings a new level of system health and management capabilities to rugged deployed systems thanks to an innovative "Reference Learn" approach.

VITA 48-REDI Conduction-cooled Versions

The high-performance VX305C-40G server blade is available as Conduction-Cooled Plug-in units according to VITA 48.2 Type 2, Secondary Side Retainer, which enables the VX305C-40G to sustain 70°C card edge temperature according to VITA 47 depending on the processing load and XMC support. The VX305C-40G is also available with a VITA 48 Ruggedized Enhanced Design Implementation (REDI) Two-Level Maintenance bottom cover option. A lab-grade air-cooled version is also available.

Kontron VPX Ecosystem

VX305C-40G boards are compatible with all Kontron 3U VPX and 6U VPX building blocks (payload boards, carriers, switches, backplanes, OS, and drivers). For instance, OpenVPX 3U Rugged Ethernet Switch features 24x 10 Gbps channels which can be bound into 40 Gigabit Ethernet links, providing Layer 2 and Layer 3 switching/routing functions. The VX3920 is available both in Forced Air-Cooled and Rugged Conduction-Cooled versions.

▶ VITA 65 (OPENVPX) SLT3-PAY-1F1F2U1TU1T1U1T-14.2.16 SLOT PROFILE

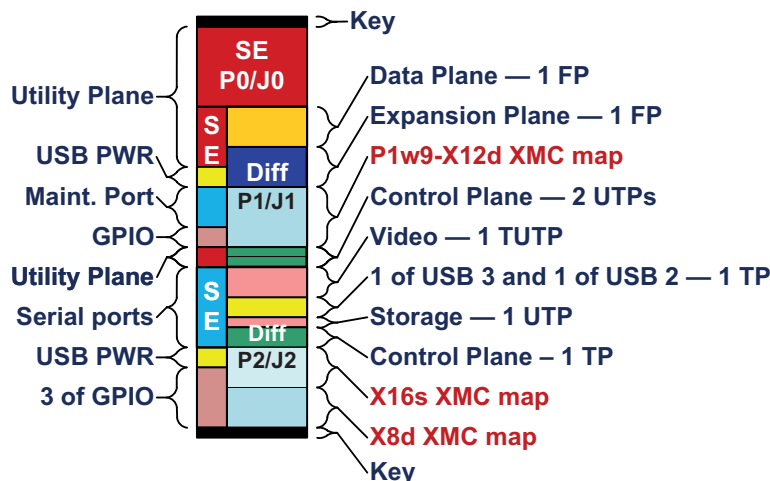

TECHNICAL INFORMATION

INTEROPERABILITY	OPEN VPX SLOT PROFILE BOARD MANAGEMENT	VITA 65 (OpenVPX) profiles : SLT3-PAY-1F1F2U1T1U1T-14.2.16 VITA46.11 IPMC on board controller
PROCESSOR	CPU, CONNECTIVITY	Intel® Xeon® D-1559 Twelve Core, TDP 45 W, 1.5 GHz/2.1 GHz Turbo (12 execution cores, 24 threads, 18 MByte Cache) PCIe gen3 ports to VPX Expansion Port and XMC 2x 10GETH links , Integrated Serial ATA host controller xHCI USB support (can be configured as SuperSpeed USB 3.0 ports) UART
	SYSTEM MEMORY	DDR4 dual channel memory with ECC, 2133 Mbits/s over 144 bits, up to 32 Gbytes, soldered
BACKPLANE	P0 CONNECTOR (POWER, UTILITY)	Power Plane: VS1=12V and 3.3V_AUX; (VS2 not used; VS3=5V not used; -12V_AUX only for XMC slot) Utility Plane: Maintenance Port, SMB
	P1 CONNECTOR (DATA , EXPANSION, CONTROL, I/O, UTILITY)	Data Plane: 1x 40Gigabit ETHERNET BASE-KR4 Expansion Plane: x4 PCIe 3.0 CONTROL PLANE: 2x 10G BASE-KR (or 1000BASE-KX) UTILITY PLANE: GPIO1, Maskable reset, GDISCRETE1, VBAT, SYSCON XMC I/O BLOCK: P1 w9 X12D XMC I/O XMC I/O BLOCK: HDMI (DisplayPort available in 2019), GETH 1000BASE-T,
	P2 CONNECTOR (I/O, UTILITY)	1x Serial TIA-232 or TIA-422 2x USB 2.0, 1x USB 3.0, 1x SATA III) XMC I/O BLOCK: X16S + X8D XMC I/O GPIO 2/3/4
I/O ENGINE	DATA PLANE ENGINE	XL710-BM 40GETH Controller (to BP P1)
STORAGE	FLASH (UEFI BIOS) EEPROM	2x16 MByte FLASH, (BIOS + Rescue) 1 256 Kbit sEEPROM dedicated to system data 1 256 Kbit sEEPROM dedicated to application data Data persistence across power cycles for Application fast changing state data (unlimited write cycles)
	USER FRAM* (1 MByte)	
MEZZANINES	XMC SLOT	1x x8 PCIe gen 3 VITA 61-2011: Support of XMC Card stacking height of 12mm as per VITA 46.9 : Mezzanine I/O routing : X12d(P1)+X8d and X16s(P2) Bottom socket: for storage modules Type M, 22 mm x 42 mm. (Top socket populated with graphics unit)
	M.2 SOCKETS	
BOARD UTILITIES	WATCHDOGS, POWER MANAGEMENT	WD: PLD-based, timeout ranging from 2 µs to 510s, IRQ, Reset, dual-stage Board Controller: power sequencing, reset handling, monitoring, failure detection
	LEDs RESET	5 LEDs reporting the board CPU health status and activity Reset (push button)
	RTC	Independant low power RTC with optional onboard battery
SOFTWARE	BIOS BSP PBIT	UEFI BIOS (Secure Boot, Measured features) Portable Linux BSP, tested with Fedora. Windows, VxWorks on demand. CMON PBIT EXPERT: BIOS Health PBIT, with system change detection (learn and compare method, no programming) CMON MONITORING: Linux health Monitoring engine. Creates Continuous flow of health data from customizable test points for remote or local use
	OPTIONAL: CBIT	

PB-VX3-40G-601 VITA 46.10 Rear Transition Module

Development on VX305C-40G boards can be started before the final system backplane is available using a rear transition module and development backplanes.

The PB-VX3-40G-601 is available for lab use and offers the following connectivity:

- ▶ One Ethernet SFP+ cage operating at 1 or 10 Gbits/s.
- ▶ One Ethernet 1000BASE-T port
- ▶ One SATA III ports
- ▶ Two serial COM ports (including maintenance port)
- ▶ One USB3 / USB2 port
- ▶ One Graphics port
- ▶ Three GPIOs

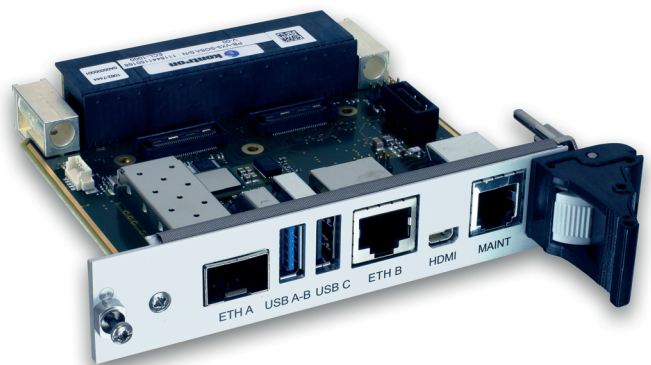

▶ ENVIRONMENTAL SPECIFICATION

	SA - AIR COOLED VERSION (NO FRONT I/O'S)	RC - RUGGED CONDUCTION-COOLED COMPLIANT WITH TYPE 1 PLUG-IN UNIT 2 LEVEL MAINTENANCE AS PER VITA48.0 AND VITA48.2 STANDARDS
CONFORMAL COATING	Optional	Standard
AIRFLOW	tbd. cfm typ. for 45 W TDP	na.
COOLING METHOD	Convection	Conduction
OPERATING TEMPERATURE	20 °C to +35 °C (LAB VERSION)	-40 °C to +70 °C
STORAGE TEMPERATURE	-45 °C to +85 °C	-45 °C to +100 °C
VIBRATION SINE (OPERATING)	20-500 Hz - 2 g	20-2.000 Hz - 5 g
RANDOM	VITA 47-Class V1	VITA 47-Class V3
SHOCK (OPERATING)	20 g/11 ms Half Sine	40 g/11 ms Half Sine
ALTITUDE (OPERATING)	-1.500 to 60.000 ft	-1,500 to 60,000 ft
RELATIVE HUMIDITY	90 % without condensation	95 % without condensation

▶ ORDERING INFORMATION

ARTICLE	PART NO.	DESCRIPTION
VX305C-40G	VX305C-40G-RCCGC051130	Conduction Cooled VX305C SBC
VX305C-40G	VX305C-40G-RCCGC05113Q	Conduction Cooled VX305C SBC with PBIT and eval Linux on SSD
VX305C-40G	VX305C-40G-SACGC05113Q	Air Cooled VX50C-40G SBC with PBIT and Eval Linux on SSD
PB-VX3-40G	PB-VX3-40G-601	Rear Transition module (Tooling equipment for lab use)

▶ Global Headquarters

Kontron S&T AG

Lise-Meitner-Str. 3-5
86156 Augsburg, Germany
Tel.: + 49 821 4086 0
Fax: + 49 821 4086 111
info@kontron.com
www.kontron.com